



DTK-120/240CM+

120/240VAC Surge Protective Device General Product Specifications

DITEK's 120/240CM+ is a durable, cost-effective SPD suitable for use in a variety of locations. It is typically used to protect pumps, motors, HVAC condensers, and incoming utility power. Backed by a ten year warranty, the DTK-120/240CM+ is an excellent choice for effective, economical protection.

**Also available in a 12-Up Contractor's Bulk Pack.
Specify DTK-120/240CM+B**

DTK-120/240CM+

Product Features

- Weatherproof enclosure
- Parallel connection for easy installation
- Diagnostic LED provides positive indication of power, ground presence, and surge protection
- Automatically resets to handle multiple surge events
- Typical Applications: A/C disconnect, small electrical panels, pool/well pumps
- Ten year limited warranty

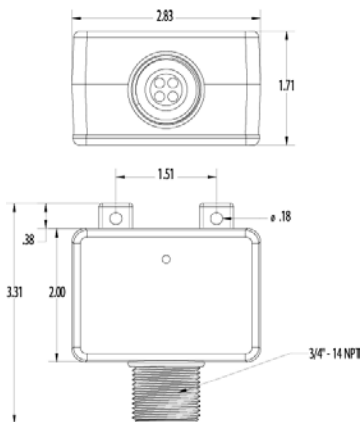

Specifications

Agency Approvals: UL 1449, 3rd Edition, cUL

Protector Type: SPD Type 2

Protection Modes: L-G, L-L

Response Time: <1ns

Temperature Range: -40°F – 185°F (-40°C – 85°C)

Maximum Humidity: 95% non-condensing

Operating Frequency: 0Hz – 400Hz

Dimensions: 2.93" x 2.83" x 1.68"
(74.4mm x 71.9mm x 42.7mm)

Connection: 3/4" threaded fitting

Weight: .5lb. (227g)

Housing: ABS

	Service Wiring	Peak Surge Current	MCOV	UL 1449, 3 rd Ed. V.P.R.	Short Circuit Current Rating	UL1449, 3 rd Ed. I _n Rating
DTK-120/240CM+	Split Φ (2W + G), 120/240VAC	72,000A/Phase 36,000A/Mode	130/260V	500V L-G, 900V L-L	10,000A	10,000A